

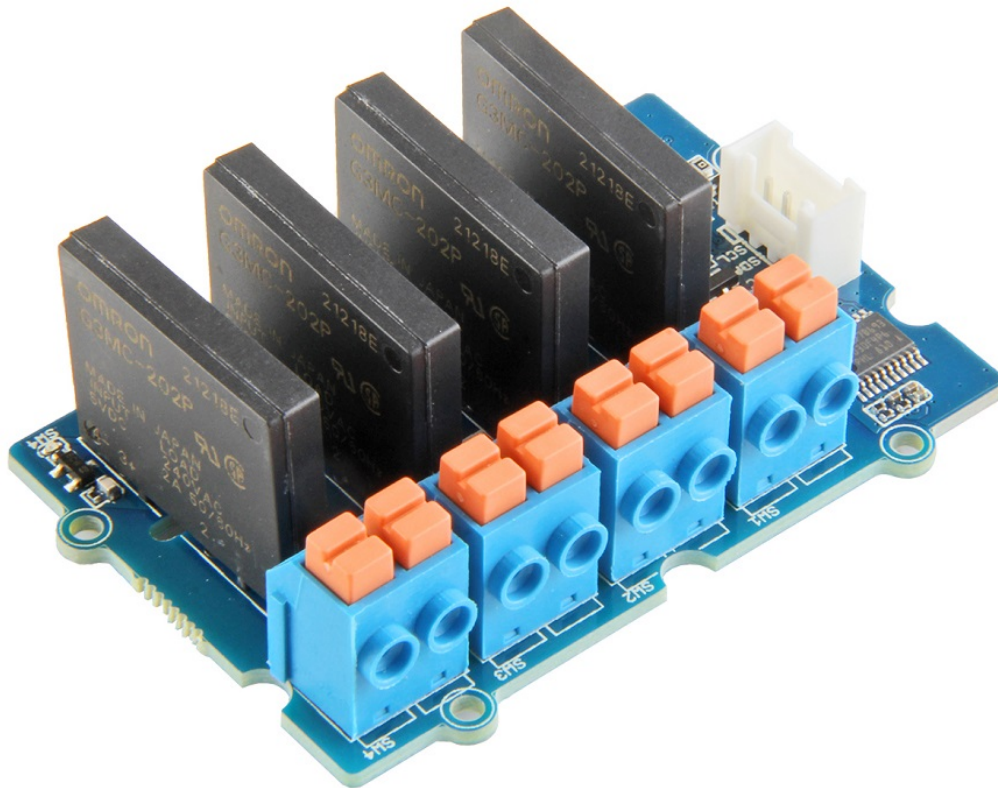

Grove - 4-Channel Solid State Relay



Instead of using coil, packaged solid-state relays(SSR) use power semiconductor devices such as thyristors and transistors, which provide a much faster switching speed than the mechanical relays. The **Grove - 4-Channel Solid State Relay** is based on the high-quality **G3MC202P** module, which allows you to use a 5VDC to control MAX. 240VAC. With the help of Grove interface, it becomes very convenient to use the SSR with your arduino.

We use an on-board [STM32F030F4P6](https://github.com/SeeedDocument/Grove-4-Channel_SPDT_Relay/raw/master/res/STM32F030F4P6.pdf) [https://github.com/SeeedDocument/Grove-4-Channel_SPDT_Relay/raw/master/res/STM32F030F4P6.pdf] to control the channels separately. The command from Arduino or other boards is transmit via the I2C interface, the on-board STM32F030F4P6 will parse the command, so that you can control the switch you want.

According to different application scenarios, we have prepared a series of solid state relays for you.

[Grove - Solid State Relay V2](http://wiki.seeedstudio.com/Grove-Solid_State_Relay_V2) [http://wiki.seeedstudio.com/Grove-Solid_State_Relay_V2]

[Grove - 2-Channel Solid State Relay](http://wiki.seeedstudio.com/Grove-2-Channel_Solid_State_Relay) [http://wiki.seeedstudio.com/Grove-2-Channel_Solid_State_Relay]

[Grove - 4-Channel Solid State Relay](http://wiki.seeedstudio.com/Grove-4-Channel_Solid_State_Relay) [http://wiki.seeedstudio.com/Grove-4-Channel_Solid_State_Relay]

[Grove - 8-Channel Solid State Relay](http://wiki.seeedstudio.com/Grove-8-Channel_Solid_State_Relay) [http://wiki.seeedstudio.com/Grove-8-Channel_Solid_State_Relay]

Get One Now 

[https://www.seeedstudio.com/Grove-4-Channel-Solid-State-Relay-p-3130.html]

Features

- Low power consumption
- Long lasting
- Optional I2c address
- Advantages over mechanical relays:
 - Solid-state relays have much faster switching speeds compared with electromechanical relays, and have no physical contacts to wear out
 - Totally silent operation

- No physical contacts means no sparking, allows it to be used in explosive environments, where it is critical that no spark is generated during switching
- Increased lifetime, even if it is activated many times, as there are no moving parts to wear and no contacts to pit or build up carbon
- Compact, thin-profile SSR of monoblock construction with an all-in-one lead frame incorporates a PCB, terminals and heat sink, which is much smaller than mechanical relays, and can integrate more channels
- Disadvantages:
 - When closed, higher resistance (generating heat), and increased electrical noise
 - When open, lower resistance, and reverse leakage current
 - Only works for AC load

Specification

Item	Value
Operating input voltage	4~6V
Rated Input Voltage	5V
Rated Load Voltage	100 to 240 VAC 50/60 Hz
Load Voltage Range	75 to 264 VAC 50/60 Hz
Load current	0.1 to 2 A
Leakage current	1.5 mA max. (at 200 VAC)
Insulation Resistance	1,000 MΩ min. (at 500 VDC)
Operate Time	Zero load power source cycle +1 ms max.

Release Time	½ of load power source cycle + 1 ms max.
Storage Temperature	-30°C to 100°C (with no icing or condensation)
Operating Temperature	-30°C to 80°C (with no icing or condensation)
Operating Humidity	45% to 85%RH
Input Interface	I ² C
Default I ² C Address	0x11 or 0x12
Available I ² C Address	0x00 ~ 0x7F
Output interface	DIP Female Blue 2 pin x4
Zero Cross	support
Certification	UL / CSA

**Attention**

You may pay attention to the **Leakage current**, 1.5mA is strong enough to drive Low power LED, so when the relay is off, the LED may still emits a faint light.

Applications

- Operations that require low-latency switching, e.g. stage light control
- Devices that require high stability, e.g. medical devices, traffic signals
- Situations that require explosion-proof, anticorrosion, moisture-proof, e.g. coal, chemical industries.

Hardware Overview

Pin Map

- 4 GND: connect this module to the system GND
- 3 VCC: you can use 5V for this module
- 2 SDA: a bidirectional input/output pin for data transmit.
- 1 SCL: a clock input pin, provide time base

- 5 LOAD2: one port of switch1 to connect to the load wire
- 6 LOAD1: the other port of switch1 to connect to the load wire

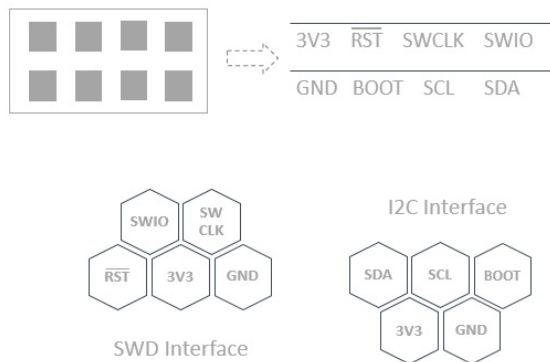
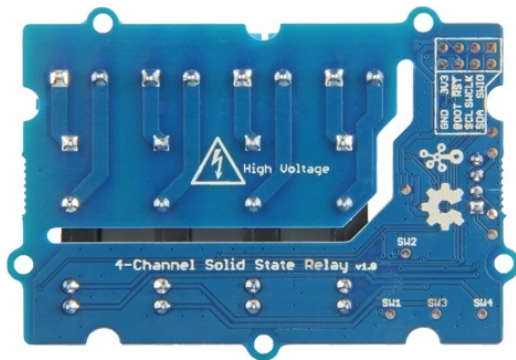

Note

- The switch 1-4 have the same pin function, so for the other switches, you can refer to **LOAD1/LOAD2**.
- On the back of the PCB, there are two interfaces: SWD and I²C. The SWD interface is used by default when programming firmware, if you want to use the I²C (actually work as the boot UART), you should set the **BOOT** High.

Schematic

Relay control

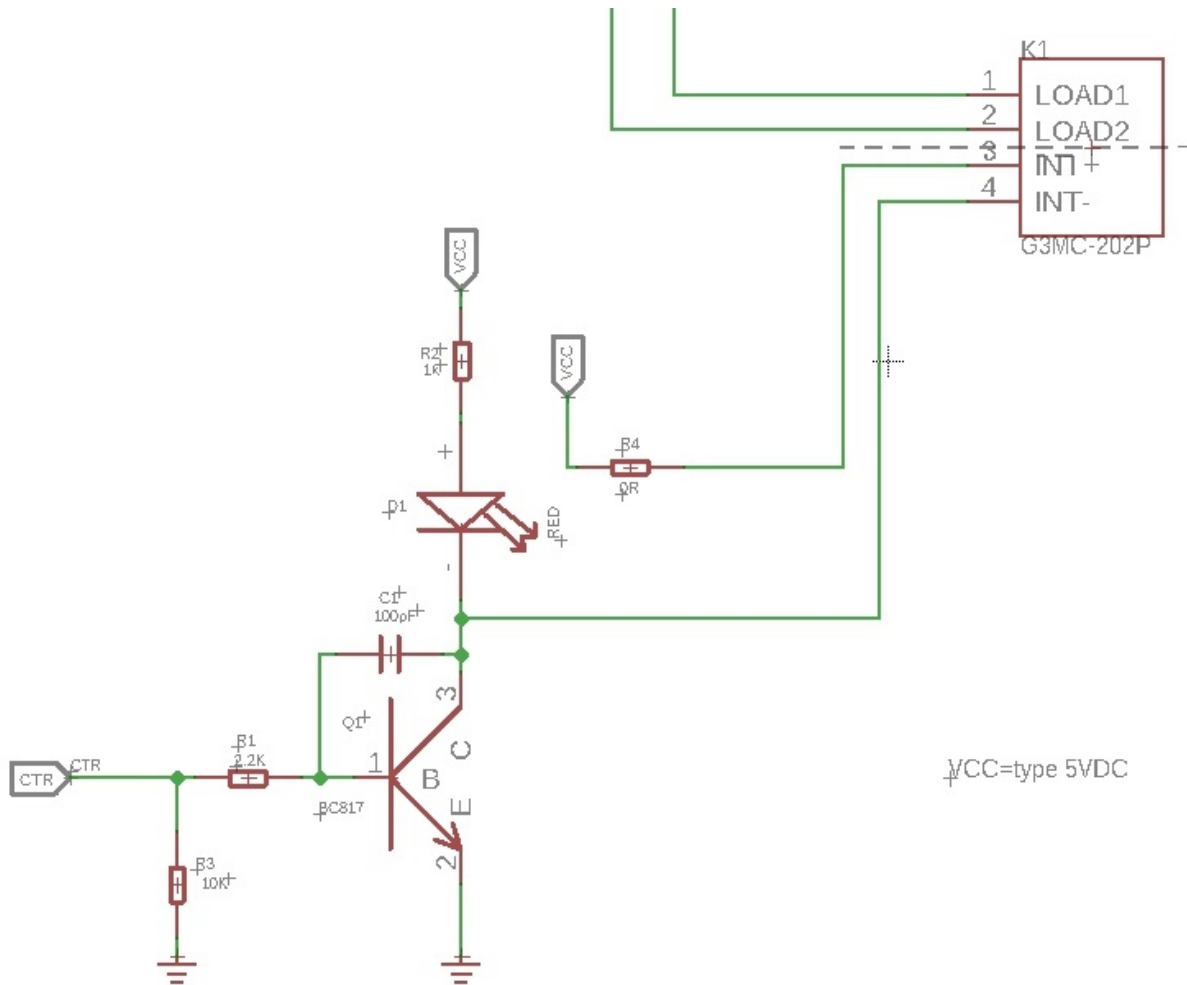

K1 is the Relay module, When a 5V voltage is applied between the **INT+** and **INT-**, the relay will be turned on. Then the **LOAD1** will connect to the **LOAD2**. We use a NPN transistors **Q1**(BC817-40) to control the voltage between the **INT+** and **INT-**.

The **CTR** is the control signal from the Arduino or other board. It is pulled down by the 10k R2, if there is no signal, the 'Gate'(port 1) of **Q1** will be 0v, and Q1 is turned off, so that the K1 will be turned off. If **CTR** becomes 5v, then the Q1 will be turned on. **INT-** of k1 will be connected to the GND of the system, for the K1 there will be 5V between **INT+** and **INT-**, so the K1 will be turned on, and the **LOAD1** will connect to **LOAD2**.

Bi-directional level shifter circuit

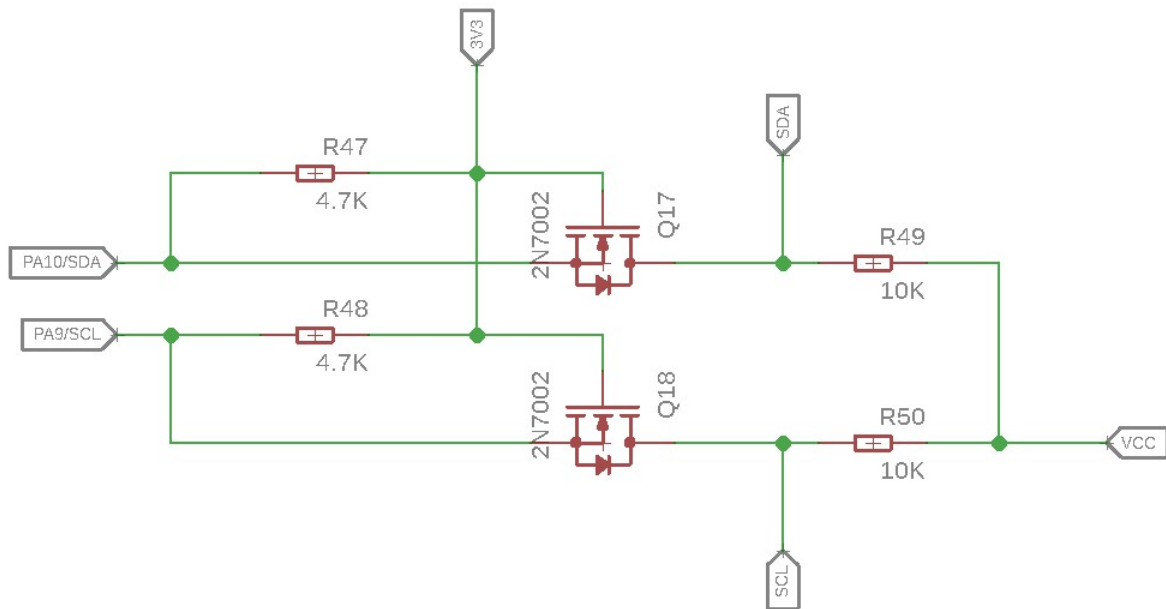

This is a typical Bi-directional level shifter circuit to connect two different voltage section of an I²C bus. The I²C bus of this sensor use 3.3V, if the I²C bus of the Arduino use 5V, this circuit will be needed. In the schematic above, **Q17** and **Q18** are N-Channel MOSFET **2N7002A** [https://github.com/SeeedDocument/Grove-I2C_High_Accuracy_Temperature_Sensor-MCP9808/raw/master/res/2N7002A_datasheet.pdf], which act as a bidirectional switch. In order to better understand this part, you can refer to the **AN10441** [https://github.com/SeeedDocument/Grove-I2C_High_Accuracy_Temperature_Sensor-MCP9808/raw/master/res/AN10441.pdf]



Note

In this section we only show you part of the schematic, for the full document please refer to the [Resources](#) [../#resources]

Platforms Supported

**Caution**



The platforms mentioned above as supported is/are an indication of the module's software or theoretical compatibility. We only provide software library or code examples for Arduino platform in most cases. It is not possible to provide software library / demo code for all possible MCU platforms. Hence, users have to write their own software library.

Getting Started

Play With Arduino

Hardware

Materials required

Seeeduino V4.2	Base Shield	Grove - 4-Chan
		
<p>Get One Now [http://www.seeedstudio.com/Seeeduino-V4.2-p-2517.html]</p>	<p>Get One Now [https://www.seeedstudio.com/Base-Shield-V2-p-1378.html]</p>	<p>Get One Now [https://www.seeedstudio.com/Grove-4-Channel-Solid-State-Relay-p-3130.html]</p>



Note

1 Please plug the USB cable gently, otherwise you may damage the port. Please use the USB cable with 4 wires inside, the 2 wires cable can't transfer data. If you are not sure about the wire you have, you can click [here](https://www.seeedstudio.com/Micro-USB-Cable-48cm-p-1475.html) [https://www.seeedstudio.com/Micro-USB-Cable-48cm-p-1475.html] to buy

2 Each Grove module comes with a Grove cable when you buy. In case you lose the Grove cable, you can click [here](https://www.seeedstudio.com/Grove-Universal-4-Pin-Buckled-20cm-Cable-%285-PCs-pack%29-p-936.html) [https://www.seeedstudio.com/Grove-Universal-4-Pin-Buckled-20cm-Cable-%285-PCs-pack%29-p-936.html] to buy.

- **Step 1.** Connect the Grove - 4-Channel Solid State Relay to the **I²C** port of the Base Shield.
- **Step 2.** Plug Grove - Base Shield into Seeeduino.
- **Step 3.** Connect Seeeduino to PC via a USB cable.

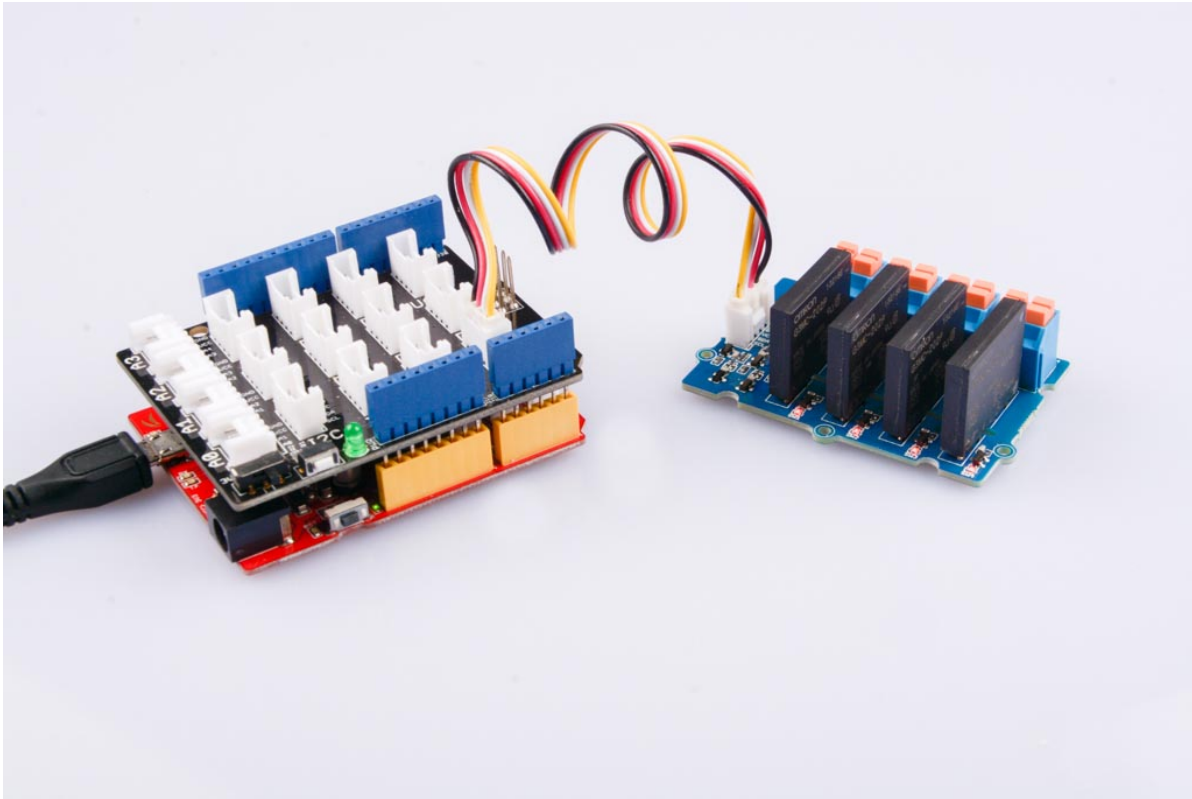

Note

If we don't have Grove Base Shield, We also can directly connect this module to Seeeduino as below.

Seeeduino	Grove - 4-Channel Solid State Relay
5V	Red
GND	Black
SDA	White
SCL	Yellow

Software



Attention

If this is the first time you work with Arduino, we strongly recommend you to see [Getting Started with Arduino](http://wiki.seeedstudio.com/Getting_Started_with_Arduino/) before the start.

- **Step 1.** Download the [Multi_Channel_Relay_Arduino](https://github.com/Seeed-Studio/Multi_Channel_Relay_Arduino_Library) Library from Github.
- **Step 2.** Refer to [How to install library](http://wiki.seeedstudio.com/How_to_install_Arduino_Library/) to install library for Arduino.
- **Step 3.** Restart the Arduino IDE. Open example via the path: **File** → **Examples** → **Multi Channel Relay Arduino Library** → **four_channel_relay_control**.

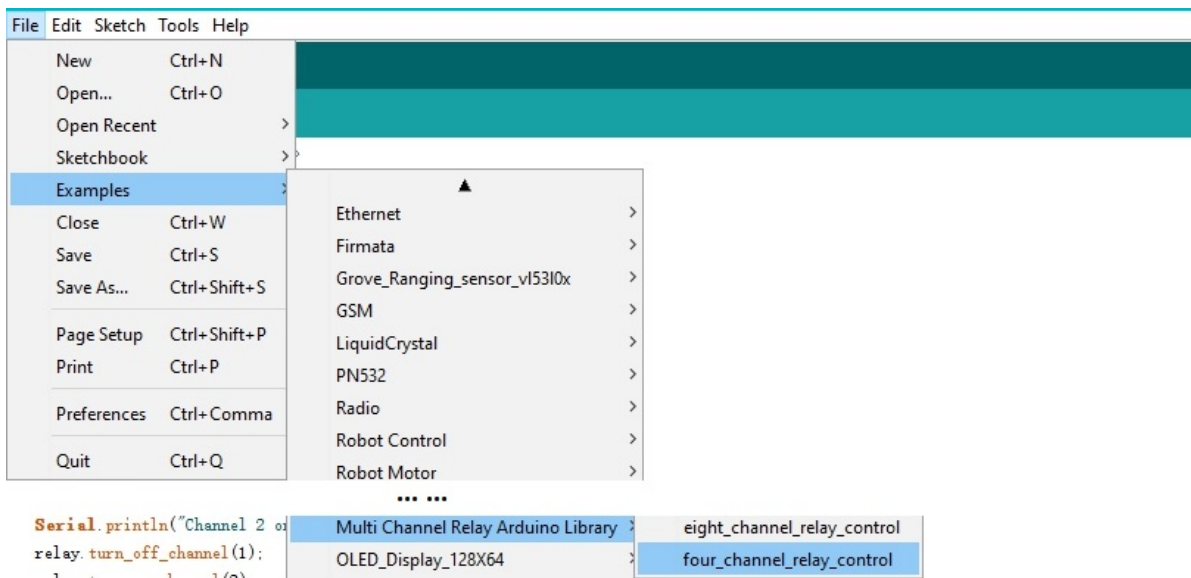

Or, you can just click the icon  in upper right corner of the code block to copy the following code into a new sketch in the Arduino IDE.

```

1  #include <multi_channel_relay.h>
2
3  Multi_Channel_Relay relay;
4
5  void setup()
6  {
7      Serial.begin(9600);
8      while(!Serial);

```

```
9
10     /* Scan I2C device detect device address */
11     uint8_t old_address = relay.scanI2CDevice();
12     if((0x00 == old_address) || (0xff == old_address)) {
13         while(1);
14     }
15
16     Serial.println("Start write address");
17     relay.changeI2CAddress(old_address, 0x11); /* Set I2C address ar
18     Serial.println("End write address");
19
20     /* Read firmware version */
21     Serial.print("firmware version: ");
22     Serial.print("0x");
23     Serial.print(relay.getFirmwareVersion(), HEX);
24     Serial.println();
25 }
26
27 void loop()
28 {
29
30     /**
31     * channle: 8 7 6 5 4 3 2 1
32     * state: 0b00000000 -> 0x00 (all off)
33     * state: 0b11111111 -> 0xff (all on)
34     */
35
36     /* Begin Controlling Relay */
37     Serial.println("Channel 1 on");
38     relay.turn_on_channel(1);
39     delay(500);
40     Serial.println("Channel 2 on");
41     relay.turn_off_channel(1);
42     relay.turn_on_channel(2);
43     delay(500);
44     Serial.println("Channel 3 on");
45     relay.turn_off_channel(2);
46     relay.turn_on_channel(3);
47     delay(500);
48     Serial.println("Channel 4 on");
49     relay.turn_off_channel(3);
50     relay.turn_on_channel(4);
51     delay(500);
52     relay.turn_off_channel(4);
53
```

```
54 relay.channelCtrl(CHANNLE1_BIT |
55                   CHANNLE2_BIT |
56                   CHANNLE3_BIT |
57                   CHANNLE4_BIT);
58 Serial.print("Turn all channels on, State: ");
59 Serial.println(relay.getChannelState(), BIN);
60
61 delay(2000);
62
63 relay.channelCtrl(CHANNLE1_BIT |
64                   CHANNLE3_BIT);
65 Serial.print("Turn 1 3 channels on, State: ");
66 Serial.println(relay.getChannelState(), BIN);
67
68 delay(2000);
69
70 relay.channelCtrl(CHANNLE2_BIT |
71                   CHANNLE4_BIT);
72 Serial.print("Turn 2 4 channels on, State: ");
73 Serial.println(relay.getChannelState(), BIN);
74
75 delay(2000);
76
77
78 relay.channelCtrl(0);
79 Serial.print("Turn off all channels, State: ");
80 Serial.println(relay.getChannelState(), BIN);
81
82 delay(2000);
83 }
```

- **Step 4.** Upload the demo. If you do not know how to upload the code, please check [How to upload code](http://wiki.seeedstudio.com/Upload_Code/) [http://wiki.seeedstudio.com/Upload_Code/].
- **Step 5.** Open the **Serial Monitor** of Arduino IDE by click **Tool-> Serial Monitor**. Or tap the `Ctrl + Shift + M` key at the same time.

**Success**

If every thing goes well, you will get the result. Meanwhile, you will see the on-board LEDs alternately lit and extinguished.

1 Scanning...

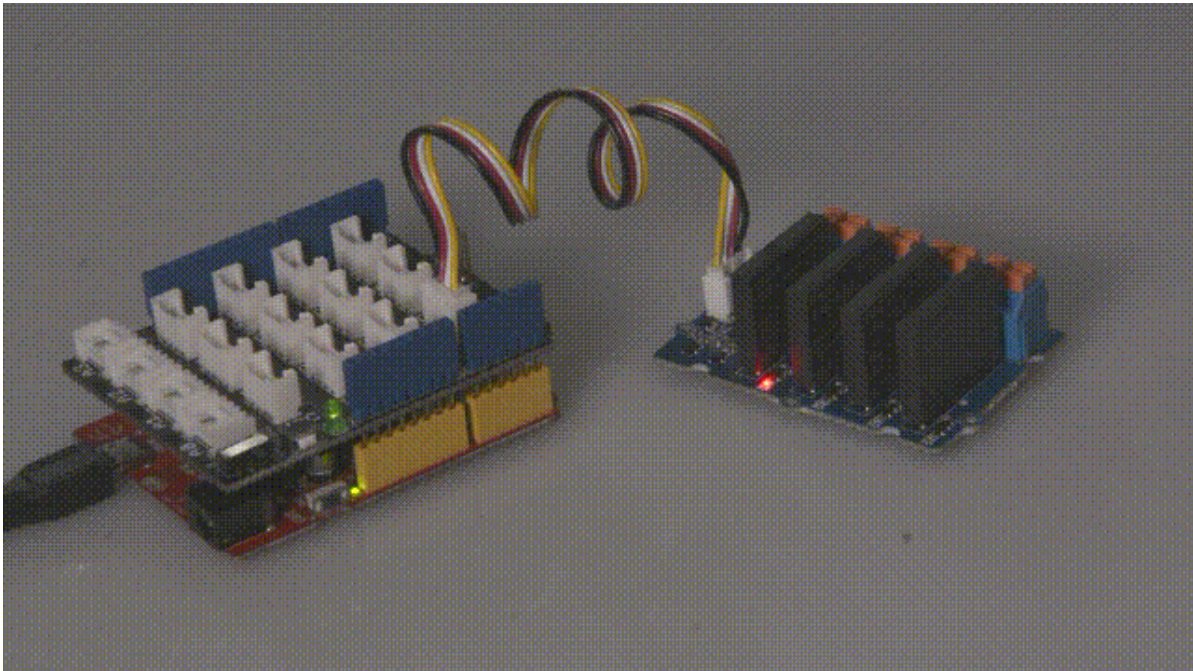

```
2 I2C device found at address 0x12 !
3 Found 1 I2C devices
4 Start write address
5 End write address
6 firmware version: 0x1
7 Channel 1 on
8 Channel 2 on
9 Channel 3 on
10 Channel 4 on
11 Turn all channels on, State: 1111
12 Turn 1 3 channels on, State: 101
13 Turn 2 4 channels on, State: 1010
14 Turn off all channels, State: 0
15 Channel 1 on
16 Channel 2 on
```

**Note**

We do not add load in this demo, if you want to check how to add load, please check the [Grove - 2-Channel Solid State Relay](http://wiki.seeedstudio.com/Grove-2-Channel_Solid_State_Relay) [http://wiki.seeedstudio.com/Grove-2-Channel_Solid_State_Relay].

Function description

Function	Description
changeI2CAddress(uint8_t old_addr, uint8_t new_addr)	change the device address,the old_addr is the current address; the new_addr is the address which you want to use. The new address can be successful only after entering the correct old address.
scanI2CDevice()	get the old_addr (current address)
getChannelState()	get the state of every channel, for instance "State: 1111", which means all channels are turned on
getFirmwareVersion()	get the firmware version burn into the on board MCU
channelCtrl(uint8_t state)	to change all channels you picked immediately, the state parameter can be: CHANNEL1_BIT or 0x01 CHANNEL2_BIT or 0x02 CHANNEL3_BIT or 0x04 CHANNEL4_BIT or 0x08 e.g. channelCtrl(CHANNEL2_BIT CHANNEL3_BIT) ,will turn on the channel 2 and channel 3 channelCtrl(0x01 0x02 0x08) , will turn on the channel 1,channel 2 and channel 4 channelCtrl(0) , will turn off all the channels.
turn_on_channel(uint8_t channel)	to turn on the single channel. e.g. turn_on_channel(3) , will turn on the channel 3
turn_off_channel(uint8_t channel)	to turn off the single channel. e.g. turn_off_channel(3) , will turn off the channel 3

In case you want to change the address, you need to set the address before use. For example, we want to change it into 0x2f. We can use the following code.

```

1 #include <multi_channel_relay.h>
2

```

```
3 Multi_Channel_Relay relay;
4
5 void setup()
6 {
7   Serial.begin(9600);
8   while(!Serial);
9
10  /* Scan I2C device detect device address */
11  uint8_t old_address = relay. ;
12  if((0x00 == old_address) || (0xff == old_address)) {
13    while(1);
14  }
15
16  Serial.println("Start write address");
17  relay.changeI2CAddress(old_address,0x2f); /* Set I2C address as
18  Serial.println("End write address");
19
20  /* Read firmware version */
21  Serial.print("firmware version: ");
22  Serial.print("0x");
23  Serial.print(relay.getFirmwareVersion(), HEX);
24  Serial.println();
25 }
```

FAQ

Q1: How to burn the firmware?

A1: We recommend you use the J-Link burner and the WSD interface to burn the firmware.

You can download the firmware here:

[Factory firmware](https://github.com/SeeedDocument/Grove-4-Channel_Solid_State_Relay/raw/master/res/Grove-4-Channel-Solid-Relay-Firmware.bin) [https://github.com/SeeedDocument/Grove-4-Channel_Solid_State_Relay/raw/master/res/Grove-4-Channel-Solid-Relay-Firmware.bin]

We recommend you use the J-flash for the software:

J-flash [<https://www.segger.com/downloads/jlink#J-LinkSoftwareAndDocumentationPack>]

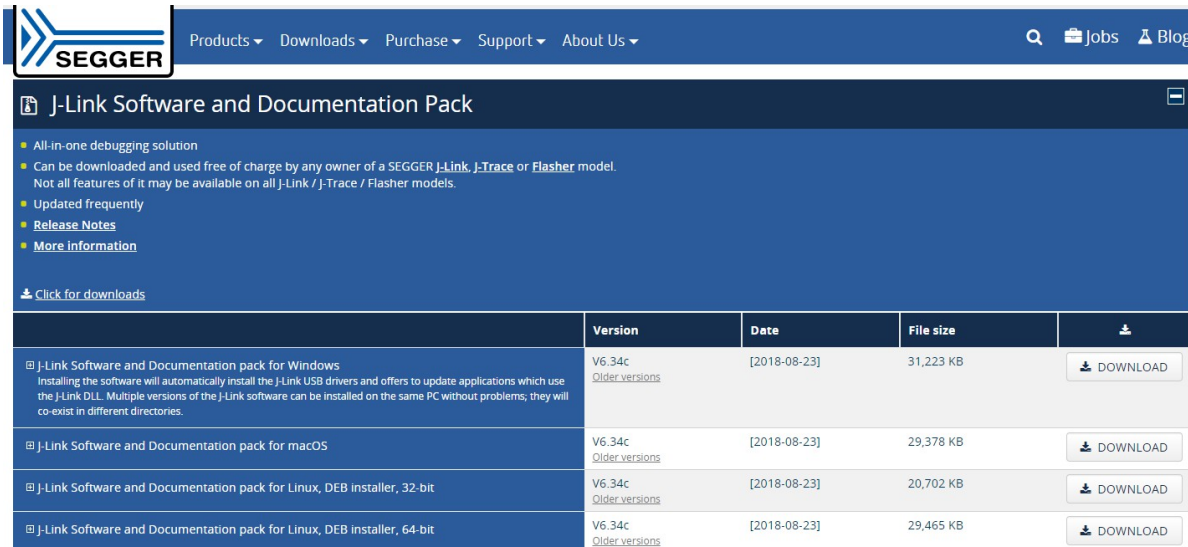

	Version	Date	File size	
<input type="checkbox"/> J-Link Software and Documentation pack for Windows <small>Installing the software will automatically install the J-Link USB drivers and offers to update applications which use the J-Link DLL. Multiple versions of the J-Link software can be installed on the same PC without problems; they will co-exist in different directories.</small>	V6.34c Older versions	[2018-08-23]	31,223 KB	DOWNLOAD
<input type="checkbox"/> J-Link Software and Documentation pack for macOS	V6.34c Older versions	[2018-08-23]	29,378 KB	DOWNLOAD
<input type="checkbox"/> J-Link Software and Documentation pack for Linux, DEB installer, 32-bit	V6.34c Older versions	[2018-08-23]	20,702 KB	DOWNLOAD
<input type="checkbox"/> J-Link Software and Documentation pack for Linux, DEB installer, 64-bit	V6.34c Older versions	[2018-08-23]	29,465 KB	DOWNLOAD

Resources

- **[Zip]** [Grove-4-Channel SPDT Relay eagle files](https://github.com/SeeedDocument/Grove-4-Channel_Solid_State_Relay/raw/master/res/Grove%20-%204-Channel%20Solid%20State%20Relay.zip) [https://github.com/SeeedDocument/Grove-4-Channel_Solid_State_Relay/raw/master/res/Grove%20-%204-Channel%20Solid%20State%20Relay.zip]
- **[Zip]** [Multi Channel Relay Arduino Library](https://github.com/Seeed-Studio/Multi_Channel_Relay_Arduino_Library/archive/master.zip) [https://github.com/Seeed-Studio/Multi_Channel_Relay_Arduino_Library/archive/master.zip]
- **[Bin]** [Factory firmware](https://github.com/SeeedDocument/Grove-4-Channel_Solid_State_Relay/raw/master/res/Grove-4-Channel-Solid-Relay-Firmware.bin) [https://github.com/SeeedDocument/Grove-4-Channel_Solid_State_Relay/raw/master/res/Grove-4-Channel-Solid-Relay-Firmware.bin]
- **[PDF]** [Datasheet of G3MC202P](https://github.com/SeeedDocument/Grove-Solid_State_Relay_V2/raw/master/res/G3MC202p.pdf) [https://github.com/SeeedDocument/Grove-Solid_State_Relay_V2/raw/master/res/G3MC202p.pdf]
- **[PDF]** [Datasheet of STM32](https://github.com/SeeedDocument/Grove-4-Channel_SPDT_Relay/raw/master/res/STM32F030F4P6.pdf) [https://github.com/SeeedDocument/Grove-4-Channel_SPDT_Relay/raw/master/res/STM32F030F4P6.pdf]

Project

This is the introduction Video of this product, simple demos, you can have a try.

Tech Support

Please do not hesitate to submit the issue into our [forum](https://forum.seeedstudio.com/)
[<https://forum.seeedstudio.com/>].

